



## **VSS Wire**

### **By TechnoPulse**

First a brief description of what the VSS wire does and some other useful information on navigation units.

#### **Vehicle Speed Sensor (VSS)**

In addition to the standard power and ground leads, many car navigation systems connect to a vehicle's Vehicle Speed Sensor (VSS) wire. The VSS wire is used by the vehicle's cruise control to determine the vehicle's speed - it serves the same function for the car navigation system. The VSS wire sends a series of pulses, anywhere from 800 to just over 1,000 per mile, and sends these pulses only when the car is in motion. If the VSS wire is not hooked up, then the unit will not realize that the car is moving at all, and will be unable to track position.

#### **Reverse Signal**

Many navigation systems also connect with the reverse (or back-up light) signal wire. The reverse wire simply lets the navigation system know which direction the vehicle is going, depending upon whether it has a positive pulse on the wire or not. If this wire is not hooked up, then the vehicle direction will not track properly, and the car navigation system won't be able to do its job.

VSS and reverse wire information for most vehicles is available from our highly-trained Technical staff - 16 hours a day, seven days a week. If the information is not available for your vehicle, they can help you figure out which wires are the ones you need.

The above Information found at <http://car-navigation.blogspot.com/>

To remove the cluster panel... DIY for Gauge Removal/Replacement  
By Paddywagon05  
[http://www.sorentosite.com/diy/gauge\\_removal/gaugeremoval.htm](http://www.sorentosite.com/diy/gauge_removal/gaugeremoval.htm)

And follow the first few steps on how to remove the cluster panel. You can stop using that DIY after you remove the three main connectors.

**Once you have completed that you can continue using this DIY.**

The photos and information I provide were gathered from a 2005 KIA Sorento. Color codes of wires should be the same for all years but I give no guarantee. If

someone finds a difference let me know and we will change the DIY to accommodate the difference.

After you unclip the three main connectors take the connector closest to the radio (U.S. Models) and it should be blue.

Compare wire colors to this picture to make sure you have a match.

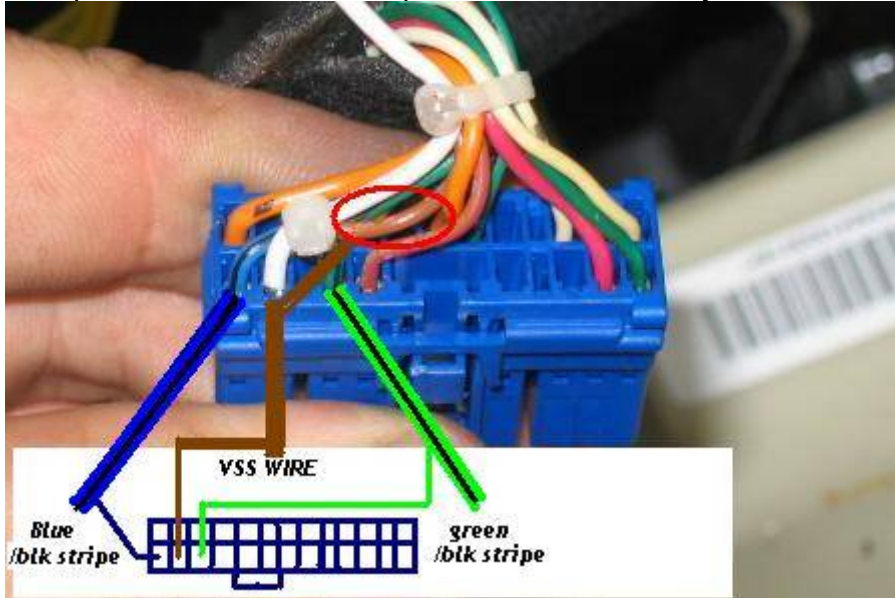

As you see I marked the 2 wires surrounding the VSS wire and the VSS wire.

Hold the connector with the tab facing you. The tab is located above my thumb in this picture.

The VSS wire is located in pin 2 in the row closest to you.

If you feel a bit more comfortable you can follow this wire to the ECM (electric control module), located behind the ash tray and connect the VSS wire there. The wires are taped and you only adding more work by doing it that way.

Connecting the wire!

Now there are 3 ways of doing this.

1. Solder - [This might void your warranty](#) so do at your own risk! If need be the VSS wire and solder can be removed leaving almost no trace of it being there in the first place.
2. Scotch lock - This also might void your warranty so do at your own risk! Scotch locks work by cutting into the wire.



3. Strip off 3/8" of wire and push into hole and secure with zip ties. This is the way I did it to prevent a voiding my warranty. I have had it this way for over a year and to this day I haven't had a problem. If you look closely at the picture I put a zip tie as close as I could get it to the connector to hold the wire in place.

Once you have figured out how you're going to secure the wire, I suggest connecting the wires back to the cluster and take a ride to check your work. Some GPS systems main set up screen shows your MPH/KM as you are moving. If it showing your speed compared to your dash then you are done. Return to the garage and put it all back together. If not go back and check the wire again, you might have to strip of a bit more.

If anyone has any other questions/comments or you might have noticed I left something out feel free to PM me.